

CHEETAH – 250

Pan (Single Axis) System

CHEETAH-250 is a member of the single axis family.

Its compact economic design gives you a highly precise movement supporting payloads up to 100kg with self-weight only 6.5 kg . Built-in control, electronics and software provide a precise, smooth motion at all speeds.



PAYLOAD
100 kg



POSITION ACCURACY
 $\pm 0.5^\circ$



SPEED
0.01 - 100 °/Sec



YAW MOVEMENT
Nx360 °

| General specification

Yaw movement	Nx360 °	
Self-Weight	6.5 kg	
Control mode	Speed / Position	
Communication	Ethernet TCP / RS232	
Environmental protection	IP66	
Power consumption	24V - 36V 3A	24V - 48V 6A
Max Payload (balanced)	100 kg	
Max Acceleration	100 °/Sec ²	
Speed (balanced)	0.01-100 °/Sec	
Position Accuracy	0.5 °	
Bandwidth	Up to 100 Hz	

| MICD

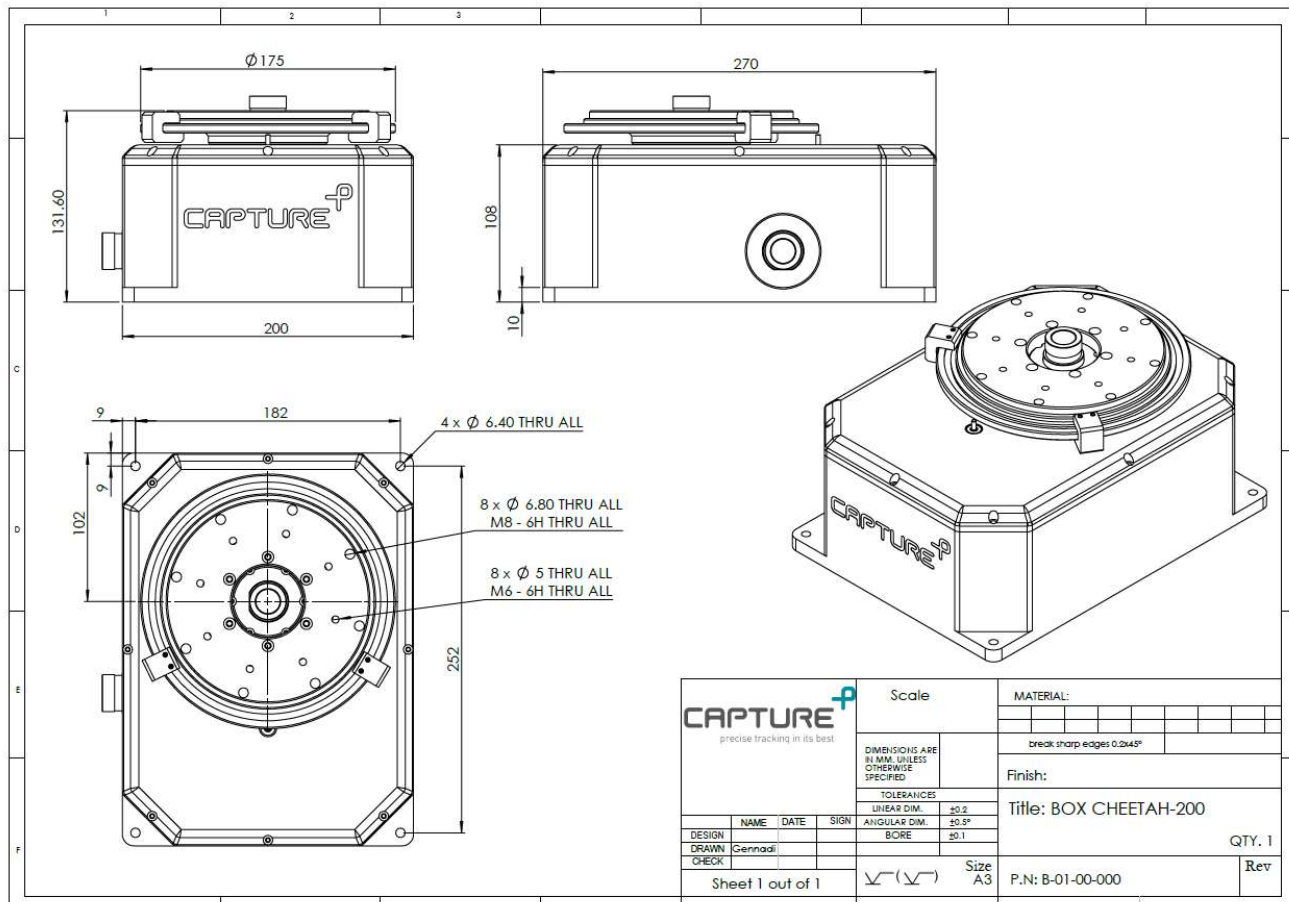

Contact us at:

CAPTURE SYSTEMS LTD,
Ravnitzky St.6, Petach Tikva, Israel
Phone: +972-3-3038108
Fax: +972-3-6200621
sales@capture-sys.com
www.capture-sys.com

